



COMMERCIAL MOWERS



**HUSTLER®**

Since 1964, Hustler Turf has been manufacturing zero-turn mowers designed to work as hard as you do. We take the same pride in our product that you take in your work, and it shows. Our commercial mowers are engineered and tested to endure.

Hustler offers a comprehensive lineup including sit-downs, stand-ons, and walk-behinds with deck sizes ranging from 34 inches to 104 inches.





# THE HUSTLER® ADVANTAGE

## SMOOTHTRAK™ STEERING

Developed over decades of experience. Precision control designed to help trim and maneuver easily around obstacles.

## INTEGRATED PARK BRAKE

Hustler was the first to integrate the parking brake into the twin-lever design. This design was patented for years and continues to be a great safety feature for operators.

## FABRICATED DECKS

Our fabricated welded-steel decks are designed to handle harsh conditions. Heavy-gauge steel and reinforced impact areas help prolong the life of the deck.

## TOUGH FRAMES

Fabricated welded-steel frames, thick front axles and forks with heavy-duty caster yokes help your mower last for years. Our frames are tested for thousands of hours on concrete test tracks with inclines and embankments.

## SIMPLE DESIGN

Who wants something you can't work on yourself? More engineering doesn't always mean more parts or more complexity. Quite the opposite. We engineer our mowers for easy serviceability with flip-up seat pans, removable floor pans, and vented pulley covers.

## PRECISION CUT QUALITY

Our decks are not only tough, but engineered to provide a clean, crisp cut. This comes from decades of learning how the airflow inside the deck stands grass blades up during the cut. The result is an even cut and defined stripes.

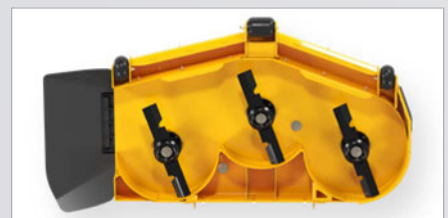

# COMMERCIAL MOWERS

## OVERVIEW

### RIDE-ON MOWERS

FASTRAK®

FASTRAK® SDX

X-ONE®

X-RIDE®

SUPER Z®

HYPERDRIVE®

DIESEL Z

SUPER 104®

### STAND-ON

SURFER PRO

SUPER S®

SUPER SF

### WALK-BEHIND

TRIMSTAR®

## OTHER PRODUCTS AVAILABLE

### RESIDENTIAL MOWERS



### GENERATORS AND INVERTERS



### PRESSURE WASHERS





# HUSTLER TECHNOLOGY

**AVAILABLE ON THE  
FOLLOWING MOWERS:**

HyperDrive  
Super 104

## HYPERDRIVE SYSTEM

Reducing the temperature of the oil in your wheel motors is key to extending the life of your hydraulic system. Hustler's exclusive HyperDrive system helps do just that with temperature regulation and tough components designed to keep your mower at peak performance. Featuring a 5-year / 3,000-hour limited warranty\*\* on the hydraulic system (warranty available on the HyperDrive mower only).



Warranty available on  
HyperDrive mower only



**9" Fan & High-Capacity Oil Cooler  
with Hot Oil Shuttle**



**Large Oil Reservoir**

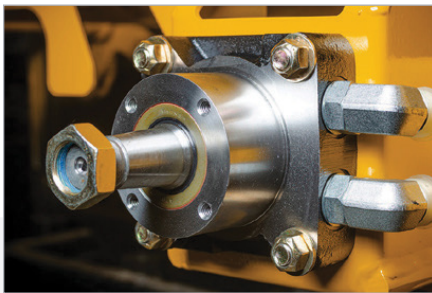

**Parker TG280® Wheel Motors**



**Industrial-Grade Slipper  
Piston Pumps**

\*\*See owner's manual for warranty details and information. Certain restrictions apply.

**AVAILABLE ON THE  
FOLLOWING MOWERS:**

X-ONE Super Z  
Super S HyperDrive  
Super SF

# VX™ DECK TECHNOLOGY

The Hustler VX Deck is engineered for extreme vacuum. The deck is designed to draw grass and leaves up into the mower blades, helping achieve a consistent cut.

- 1. ANTI-SCALP WHEELS**  
Located outside the deck to help keep the air channel unobstructed.
- 2. HIGH SAIL BLADES**  
Helps generate lift.
- 3. BLADE BOLT PROTECTORS**  
Helps protect the bolts from being sheared off from uneven ground or hard debris.
- 4. 7 GA DECKPLATE WITH 7 GA STAMPED SPINDLE MOUNTS**  
Designed for durability and long life in sandy conditions.
- 5. FRONT OF THE DECK**  
11 GA bull nose/ramp.
- 6. FULL WIDTH AIR CHANNEL**  
Open across the entire front deck, designed to allow crossflow in front of the cutting chamber to aid vacuum across the width of the deck.
- 7. "SHARP" WRAPPER INTERSECTIONS**  
Help minimize air flow across the back of the deck.
- 8. INTERNAL FRONT WALL HEIGHT**  
Designed to help grass stand back up prior to being out.
- 9. "CUT-OFF" BAFFLE**  
Designed to help throughput and balance of airflow through the deck.
- 10. FRONT WALL TO BLADE DISTANCE**  
Opened to allow for adequate grass throughput and aid in provide even clipping dispersal.

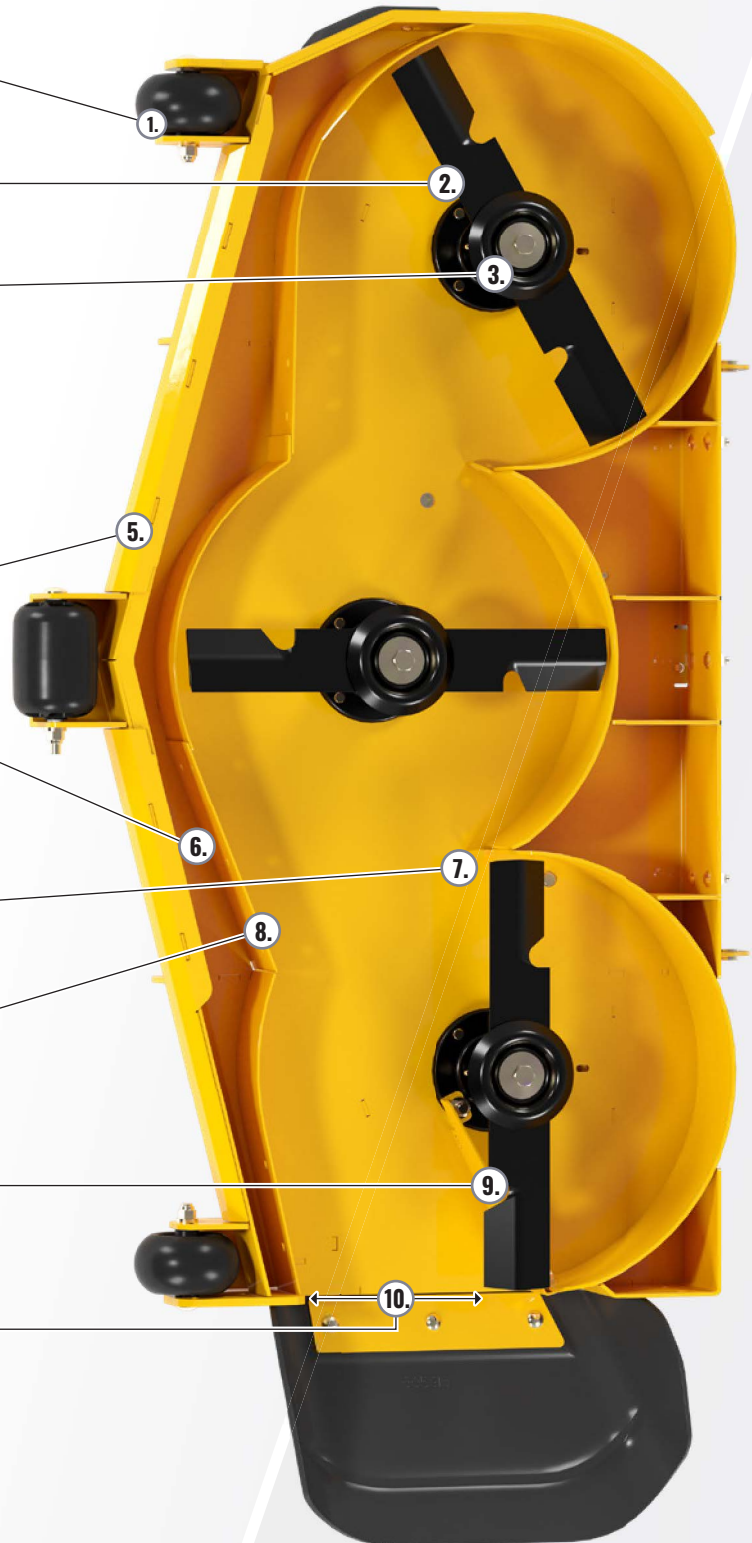



- ① ANTI-SCALP WHEELS
- ② HIGH SAIL BLADES
- ③ BLADE BOLT PROTECTORS
- ④ 7 GA DECKPLATE WITH 7 GA STAMPED SPINDLE MOUNTS
- ⑤ FRONT OF THE DECK
- ⑥ FULL WIDTH AIR CHANNEL
- ⑦ "SHARP" WRAPPER INTERSECTIONS
- ⑧ INTERNAL FRONT WALL HEIGHT
- ⑨ "CUT-OFF" BAFFLE
- ⑩ FRONT WALL TO BLADE DISTANCE





**AVAILABLE ON THE  
FOLLOWING MOWERS:**

Super Z  
HyperDrive  
Diesel Z  
X-Ride

# VX4<sup>®</sup> DECK TECHNOLOGY

The VX4 Deck combines four performance features to help provide a quick, clean, and professional looking cut: Versatility, Velocity, Vacuum, and Volume. The combination allows professionals to move grass through the deck efficiently and consistently.

## DECK FEATURES

- 1. FORMED DISCHARGE STIFFENER**  
For rigidity to help movement at the discharge opening.
- 2. DECKPLATE REINFORCEMENT**  
7 GA steel along the top of the deck is engineered to provide continuous support from front to back and to help prevent the deck from bending.
- 3. STAMPED DECK DOUBLERS**  
Stamped 7 GA steel around the spindle mount areas creates a 3.8" total thickness designed to support the spindle and add strength to the deck.
- 4. FORMED BUMP BAR**  
Angled contact surface formed and engineered to help protect the deck by deflecting impacts.
- 5. WEAR GUARD**  
Poly replaceable wear plate helps protect deck trim edge and obstacles from damage.
- 6. DECK GUARDS**  
 $\frac{3}{8}$ " thick guard helps protect the integrity of the deck from side impacts.

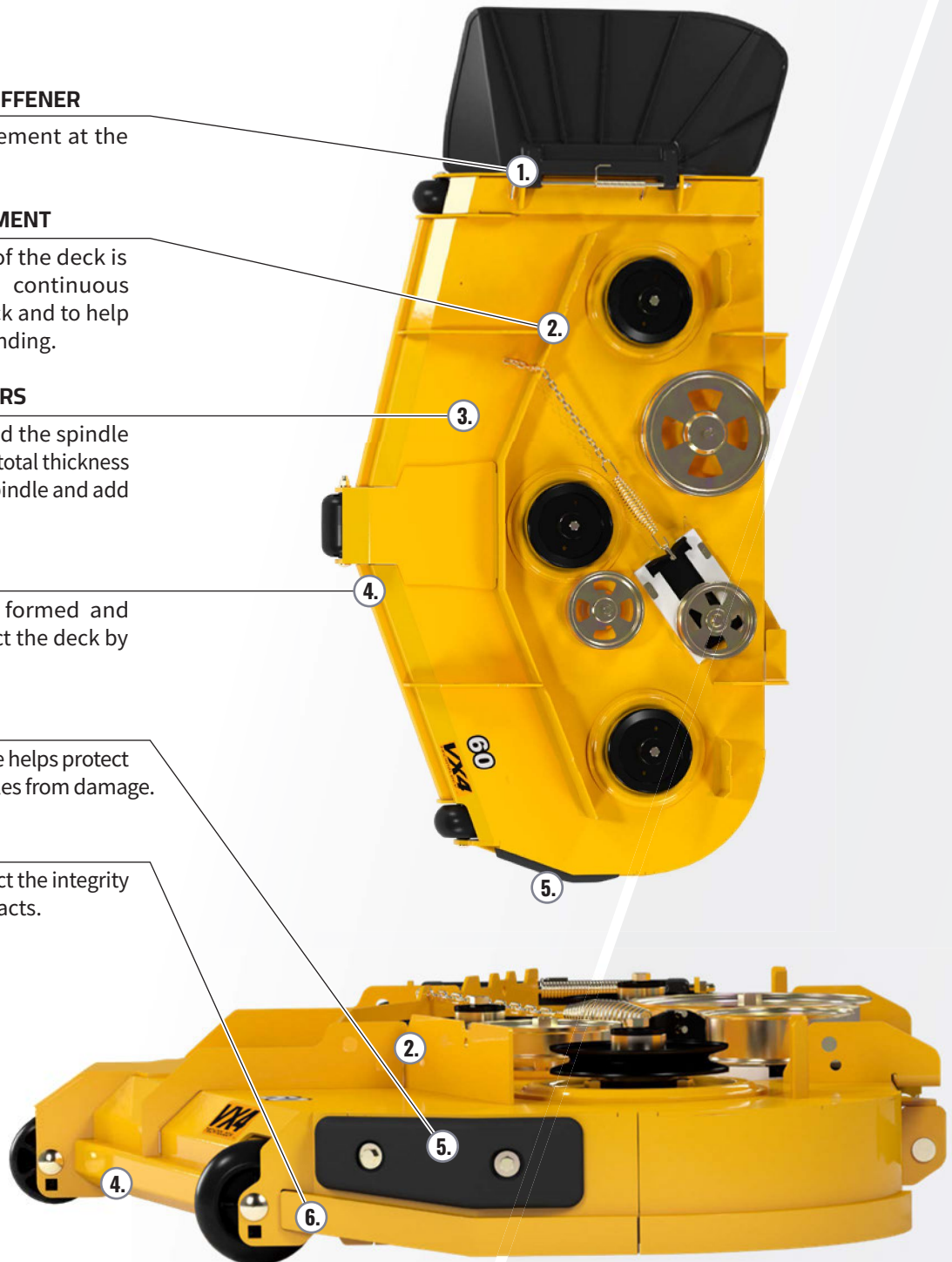

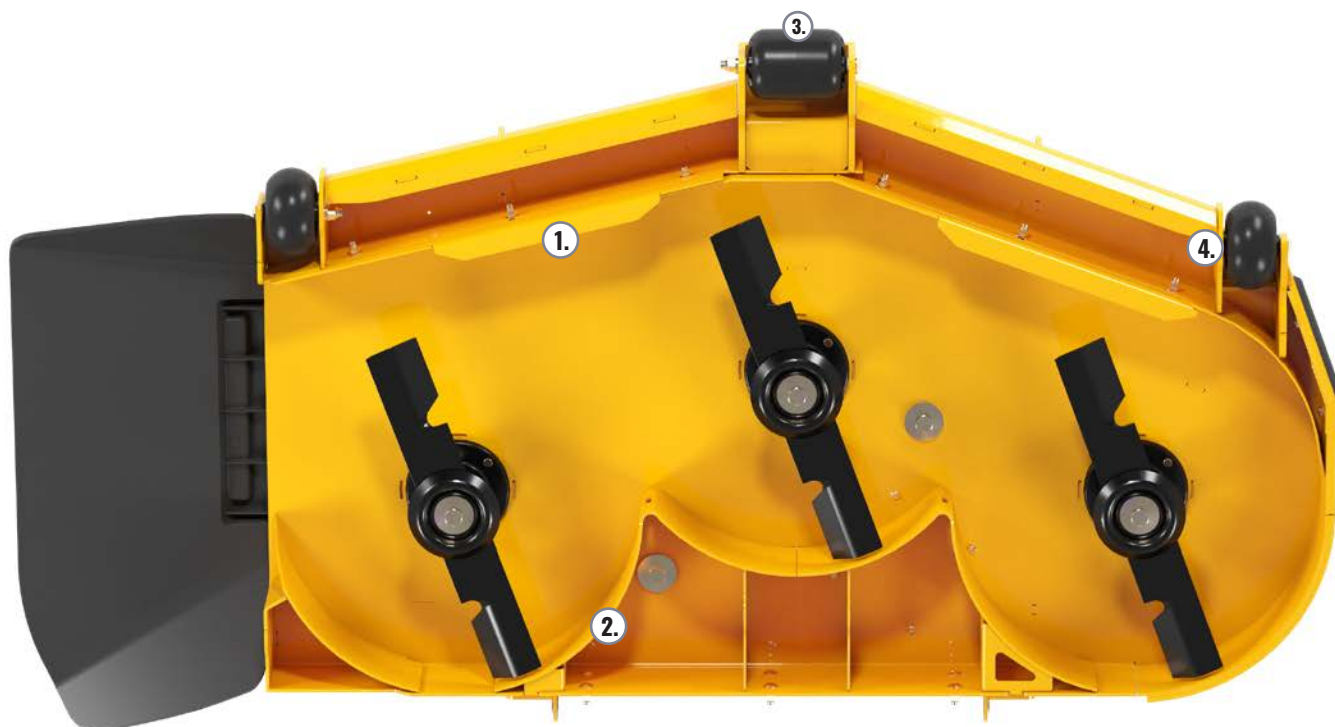

## UNDERSIDE OF DECK FEATURES

- 1. ADJUSTABLE FRONT BAFFLE**  
Allows for adjusting the deck according to mowing season and grass type for a precise cut.
- 2. DECK WRAPPERS**  
7 GA deck wrappers help fortify the deckplate.
- 3. FRONT ANTI-SCALP WHEEL**  
Anti-scalp wheels with internal bushings help protect.
- 4. HEAVY GAUGE MOUNTS**  
Angled contact surface formed and engineered to help protect the deck by deflecting impacts.

## SPINDLE IMPROVEMENTS

### DEBRIS SHIELD

Designed to protect the top bearing from water, dirt, and debris.

### RELIEF FITTING

Designed to protect seals from overpressure when filling with grease.

### DUCTILE CAST IRON HOUSING

Helps provide protection for the spindles.

### GREASE ZERK

Easy access to grease the spindles.

### BLADE BOLT PROTECTORS

Designed to protect the bolts from being sheared off from uneven ground or hard debris.

# FASTRAK

DECK SIZE / ENGINE		
48"	22 HP*	Kawasaki® FT691
48" RD	22 HP*	Kawasaki® FT691
54"	22 HP*	Kawasaki® FT691
54" RD	22 HP*	Kawasaki® FT691
60"	24 HP*	Kawasaki® FT730

✔ 4YR/750HR Limited Warranty\*\*



**HIGH-BACK SUSPENSION SEAT**  
High-back seat with suspension to help shield the operator from bumps and EVC cushion designed to help take pressure off the tailbone and lower back.



**COMMERCIAL-GRADE KAWASAKI® FT ENGINE**  
With Vortical Air Filtration. Cleans debris to help extend engine life.



**DUAL ROTO-MOLDED FUEL TANKS**  
8.5 gallon fuel capacity and dual fuel gauges.

\*As rated by the engine manufacturer.

\*\*See owner's manual for warranty details and information. Certain restrictions apply.



UPGRADES FOUND ON THE

# FASTRAK SDX

COMPARED TO THE FASTRAK

DECK SIZE / ENGINE		
48"	22 HP*	Kawasaki® FX691
54"	22 HP*	Kawasaki® FX691
60"	23.5 HP*	Kawasaki® FX730

## MORE WARRANTY COVERAGE

- ✓ 4YR/1000HR Limited Warranty\*\*  
Compared to 4YR / 750 HR limited warranty



**EXTRA HIGH-BACK SUSPENSION SEAT**  
Higher backrest and more bolstered back cushion.



**KAWASAKI® FX ENGINE**  
Full commercial remote canister air cleaner



**LARGER TRANSMISSIONS**  
Hydro-Gear® ZT-3400™

\*As rated by the engine manufacturer.

\*\*See owner's manual for warranty details and information. Certain restrictions apply.

# FASTTRAK

## SERIES

### SHARED FEATURES

**1. MAGNETIC TOP PIN DECK LIFT SYSTEM**

Adjust the deck height between 1.5"–4.5" with your foot.

**2. CAST DECK HANGERS**

Designed to help improve durability.

**3. EASY SERVICEABILITY**

Flip-up seat pan, removable floor pan, and toolless removable pulley covers to make maintenance easy and simple.

**4. WELDED STEEL DECK**

10 GA welded fabricated steel.

**5. FRONT AND REAR TIE DOWNS**

1.5" x 3" tubular steel fabricated frame with front and rear tie downs.

**6. SMOOTHTRAK™ STEERING**

Precision control designed to help trim and maneuver easily around obstacles.

**7. LESS CLUTTER UNDER SEAT**

Provides airflow aiding in keeping transmissions cooler.

**8. TRANSMISSIONS**

Serviceable Hydro-Gear® transmissions.





# FASTRAK SERIES SHARED FEATURES



- ①. MAGNETIC TOP PIN DECK LIFT SYSTEM
- ②. CAST DECK HANGERS
- ③. EASY SERVICEABILITY
- ④. WELDED STEEL DECK
- ⑤. FRONT AND REAR TIE DOWNS
- ⑥. SMOOTHTRAK™ STEERING
- ⑦. LESS CLUTTER UNDER SEAT
- ⑧. HYDRO-GEAR® TRANSMISSIONS

## HYDRO-GEAR® TRANSMISSIONS





# X-ONE

DECK SIZE / ENGINE		
52"	27 HP*	Kawasaki® FX850
54" RD	27 HP*	Kawasaki® FX850
60"	27 HP*	Kawasaki® FX850
60" RD	27 HP*	Kawasaki® FX850
60"	29.5 HP*	Kawasaki® FX850 EFI
72"	27 HP*	Kawasaki® FX850
72:"	29.5 HP*	Kawasaki® FX850 EFI

✓ 5YR/1200HR Limited Warranty\*\*  
First 2 years no hour limit.



## VX™ DECK

Fabricated 7 GA steel engineered for extreme vacuum to deliver an excellent after cut appearance.



## 13M™ SUSPENSION SEAT

High-back seat with adjustable armrests and 3-inch travel range.



## COMMERCIAL-GRADE ENGINES

Kawasaki® FX, Vanguard® BigBlock™ w/ Oil Guard, and KOHLER® Command Pro Engine options backed by 3-year limited warranties\*\*

\*As rated by the engine manufacturer.

\*\*See owner's manual for warranty details and information. Certain restrictions apply.

# X-ONE

## PRODUCT FEATURES

1. **FABRICATED FRAME**

1.5" x 3.0" steel single piece fabricated frame.

2. **FOOT OPERATED DECK LIFT**

Easily adjust the deck height between 1"-5.5" with your foot.

3. **VX DECK**

Fabricated 7GA steel engineered for extreme vacuum for performance and cut quality.

4. **SMOOTHTRAK™ STEERING**

Precision control to help trim and maneuver easily around obstacles.

5. **COMMERCIAL-GRADE TORQUE**

Hydro-Gear ZT-4400™.

6. **I3M™ SEAT**

High-back seat with adjustable armrests and 3-inch suspension travel range.





# X-RIDE™

## DECK SIZE / ENGINE

60" 34.5HP\* Kawasaki® FX820 EVO EFI

✓ 5YR/1200HR Limited Warranty\*\*  
First 2 years no hour limit.



**FULL SUSPENSION  
PLATFORM**



**FAST TOOLLESS ONE-  
HAND ADJUSTABILITY**



**5 LEVELS OF  
ADJUSTABILITY**



**4" OF TRAVEL**

\*As rated by the engine manufacturer.

\*\*See owner's manual for warranty details and information. Certain restrictions apply.



# X-RIDE™

## PRODUCT FEATURES

### 1. FABRICATED FRAME

1.5" x 3.0" steel single piece fabricated frame.

### 2. FOOT OPERATED DECK LIFT

Easily adjust the deck height between 1"-5.5" with your foot.

### 3. VX4 DECK

Fabricated 7GA steel engineered for extreme vacuum for performance and cut quality.

### 4. SMOOTHTRAK™ STEERING

Precision control to help trim and maneuver easily around obstacles.

### 5. COMMERCIAL-GRADE SEAT

Bolstered high-back seat with padded armrests and adjustable back.

### 6. CUSTOM RIDE TECHNOLOGY

Custom ride technology separates the platform from the frame which pivots along the front footrest. Dial-in comfort with 5-adjustment positions, coil-over-shock suspension system, and 4" of total suspension travel.



# SUPER Z

DECK SIZE / ENGINE		
54"	27 HP*	Kawasaki® FX850
60"	27 HP*	Kawasaki® FX850
60"	35 HP*	Kawasaki® FX1000
60" RD	35 HP*	Kawasaki® FX1000
60" VX	35 HP*	Kawasaki® FX1000
60"	38.5 HP*	Kawasaki® FX1000 EFI
72"	35 HP*	Kawasaki® FX1000
72" RD	35 HP*	Kawasaki® FX1000
72"	38.5 HP*	Kawasaki® FX1000 EFI

✔ 5YR/1200HR Limited Warranty\*\*  
First 2 years no hour limit.

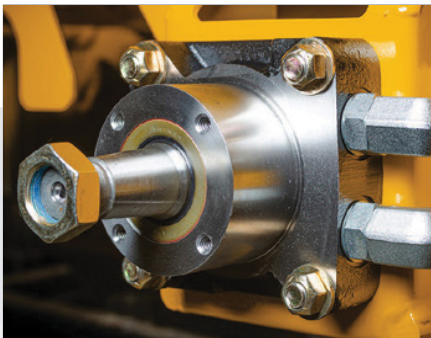

**COMMERCIAL-GRADE TORQUE**  
Hydro-Gear 21 cc PY pumps and Parker TG wheel motors.



**HEAVY-DUTY HYDRAULICS**  
with 3 GAL oil reservoir, oil cooler w/ fan, & hot oil shuttle.



**KAWASAKI FX & FX EFI ENGINES**  
Kawasaki FX1000 EFI also available.

\*As rated by the engine manufacturer.

\*\*See owner's manual for warranty details and information. Certain restrictions apply.



# SUPER Z

## PRODUCT FEATURES

### 1. FOOT OPERATED DECK LIFT

Easily adjust the deck height between 1"–5.5" with your foot.

### 2. EASY SERVICEABILITY

Flip-up seat pan, removable floor pan, and vented pulley covers for easy and simple maintenance.

### 3. VX4® DECK

Fabricated 7GA steel engineered for extreme vacuum for performance and cut quality.

### 4. SMOOTHTRAK™ STEERING

Precision control to help trim and maneuver easily around obstacles.

### 5. LARGE FUEL CAPACITY

Dual fuel tank w/12 gallon fuel capacity.

### 6. 13M™ SUSPENSION SEAT

High-back seat with adjustable armrests and 3-inch suspension travel range.





# HYPERDRIVE

DECK SIZE / ENGINE		
60"	35 HP*	Kawasaki® FX1000
60" RD	38.5 HP*	Kawasaki® FX1000 EFI
60" VX	38.5 HP*	Kawasaki® FX1000 EFI
60"	40 HP*	Vanguard® BigBlock EFI w/ Oil Guard
72"	35 HP*	Kawasaki® FX1000
72"	38.5 HP*	Kawasaki® FX1000 EFI
72" RD	38.5 HP*	Kawasaki® FX1000 EFI
72"	40 HP*	Vanguard® BigBlock® w/ Oil Guard

✓ 5YR/1200HR Limited Warranty\*\*  
First 2 years no hour limit.



**HYPERDRIVE® HYDRO SYSTEM**  
Features industrial-grade pumps and motors to handle tough jobs and long days.



**OPTIONAL VANGUARD BIG BLOCK ENGINE w/ OIL GUARD**  
500 hour oil change.



**INDUSTRIAL-GRADE SLIPPER PISTON PUMPS**  
These kinds of pumps are typically found on larger equipment like skid steers.

\*As rated by the engine manufacturer.

\*\*See owner's manual for warranty details and information. Certain restrictions apply.

# HYPEDRIVE

## PRODUCT FEATURES

### 1. FOOT OPERATED DECK LIFT

Easily adjust the deck height between 1"-5.5" with your foot.

### 2. EASY SERVICEABILITY

Flip-up seat pan, removable floor pan, and vented pulley covers for easy and simple maintenance.

### 3. VX4® DECK

Fabricated 7GA steel engineered for extreme vacuum for performance and cut quality.

### 4. SMOOTHTRAK™ STEERING

Precision control to help trim and maneuver easily around obstacles.

### 5. AMPLE TORQUE

Danfoss DDC-20 pumps and Parker TG wheel motors.

### 6. 13M™ SUSPENSION SEAT

High-back seat with adjustable armrests and 3-inch suspension travel range.





# DIESEL Z

DECK SIZE / ENGINE		
60"	25 HP*	Perkins®
60" RD	25 HP*	Perkins®
72"	25 HP*	Perkins®
72" RD	25 HP*	Perkins®

✓ 5YR/1200HR Limited Warranty\*\*  
First 2 years no hour limit.



**SERVICE ACCESS**  
Removable back cover for maintenance access.



**13M™ SUSPENSION SEAT**  
High-back seat with adjustable armrests and 3-inch travel range.



**PATENTED BELT DRIVE SYSTEM**  
Helps provide long-life to the machine.

\*As rated by the engine manufacturer.

\*\*See owner's manual for warranty details and information. Certain restrictions apply.



# DIESEL Z

## PRODUCT FEATURES

**1. FORMED BUMP BAR**

Angled contact surface formed and engineered to protect the deck by deflecting impacts.

**2. VX4® DECK**

Fabricated 7 GA steel deck engineered to help move grass at high speed while maintaining cut-quality.

**3. REINFORCED EDGE**

1.5" x .375" steel bar.

**4. TOP ACCESS**

Top hatch opens for access to service points.

**5. 14.4 US GALLON FUEL CAPACITY**

**6. FILTER ACCESS**

Easy access to slide out filter.



# SUPER 104

DECK SIZE / ENGINE		
104" RD	38.5HP*	Kawasaki® FX1000 EFI
104" RD	40HP*	Vanguard® BigBlock EFI w/ Oil Guard

✓ 5YR/1200HR Limited Warranty\*\*  
First 2 years no hour limit.



**HYPERDRIVE HYDRO SYSTEM**  
Features industrial-grade pumps and motors to handle tough jobs and long days.



**104" WIDTH OF CUT**  
Widest zero-turn available from Hustler Turf.



**80" TRANSPORT WIDTH**  
Fits most trailers making it easy to transport from job-to-job.

\*As rated by the engine manufacturer.

\*\*See owner's manual for warranty details and information. Certain restrictions apply.



# SUPER 104

## PRODUCT FEATURES

- 1. HYPERDRIVE® HYDRO SYSTEM**  
Features industrial-grade pumps and motors to handle tough jobs and long days.
- 2. COMMERCIAL-GRADE ENGINES**  
Vanguard Big Block™ EFI with Oil Guard, Kawasaki FX1000 EFI engine options.
- 3. SMOOTHTRAK STEERING**  
Precision control designed to help trim and maneuver easily around obstacles.
- 4. HYDRAULIC WINGS**  
Easily Raise and lower wings for transporting
- 5. HYDRAULIC DECK HEIGHT ADJUSTMENT**  
Raising and lowering your cutting height is easy.
- 6. I4M SUSPENSION SEAT**  
High-back seat with adjustable armrests and 4-inch travel range.

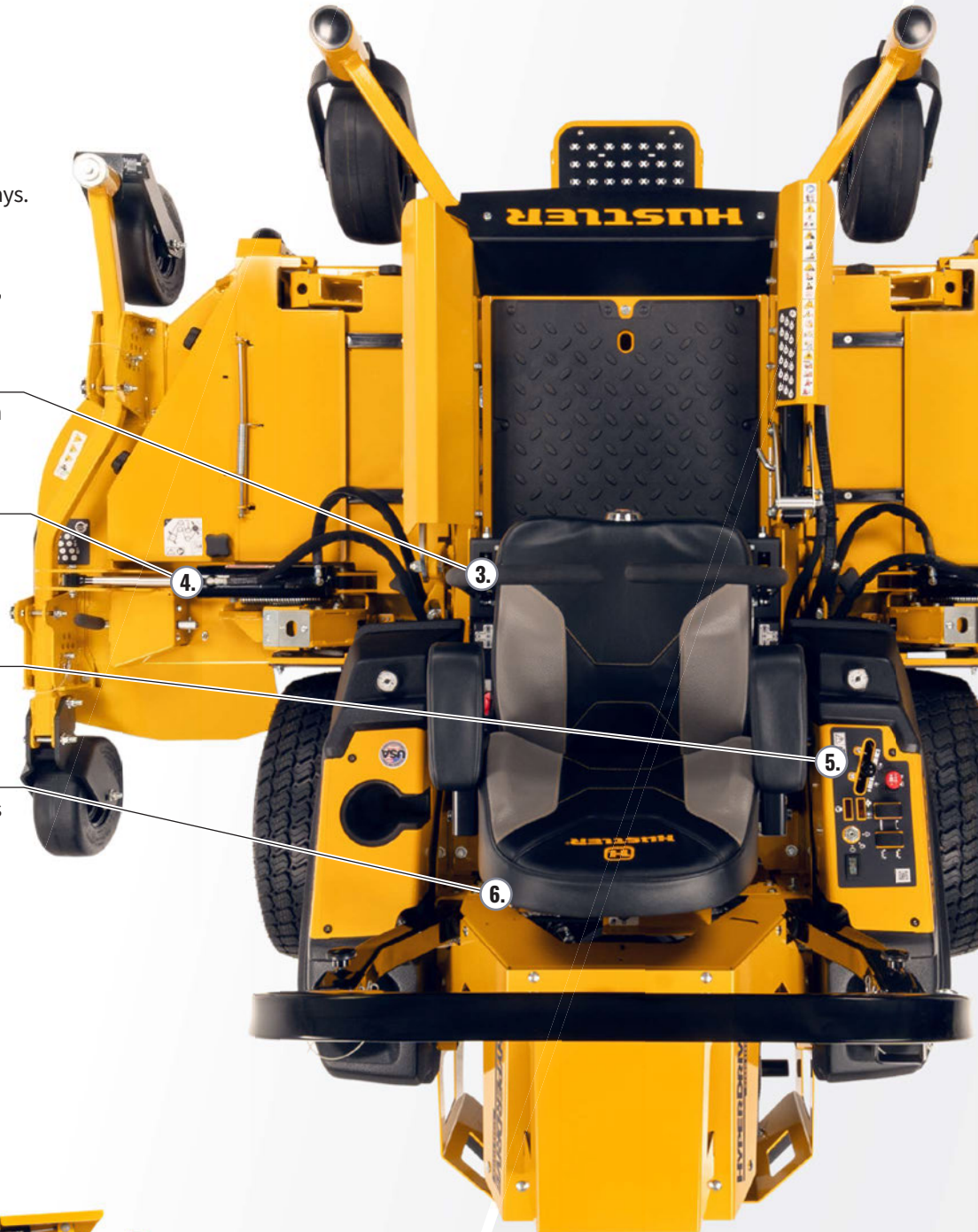



# SURFER PRO

## DECK SIZE / ENGINE

34"	15 HP*	Kawasaki® FS541
48"	15 HP*	Kawasaki® FS541

- ✓ 3YR/300HR Residential Limited Warranty\*\*  
or 2YR/300HR Residential Limited Warranty\*\*



### KAWASAKI FS ENGINE

15 HP\* Commercial FS541 V-Twin Engine.



### FABRICATED DECKS

Fabricated 7 GA and 11 GA steel decks, engineered for extreme vacuum performance and cut quality.



### SMOOTHTRAK STEERING

Precision control designed to help trim and maneuver easily around obstacles.

\*As rated by the engine manufacturer.

\*\*See owner's manual for warranty details and information. Certain restrictions apply.

# SURFER PRO

## PRODUCT FEATURES

- 1. SEMI PNEUMATIC FRONT TIRES**  
11" front tires.
- 2. KAWASAKI FS541 ENGINE**  
15 HP\*
- 3. 34" & 48" DECKS**  
Fabricated steel decks for durability.
- 4. SMALL FOOTPRINT**  
Just 59" in length for easy storage and trailering.
- 5. CUT HEIGHT ADJUSTMENT**  
Hand operated lever and pin to easily adjust deck/cutting height.
- 6. 2 GALLON FUEL CAPACITY**
- 7. HYDRO-GEAR ZT-1800 TRANSMISSIONS**
- 8. 18" DRIVE TIRES**  
Helps provide stability and traction.
- 9. PARK BRAKE**  
Hand operated lever to set the park brake.





# SUPER S

DECK SIZE / ENGINE		
36"	19 HP*	Kawasaki® FX600
48"	22 HP*	Kawasaki® FX691
52"	27 HP*	Kawasaki® FX850
52"	29.5 HP*	Kawasaki® FX850 EFI
60"	27 HP*	Kawasaki® FX850
60"	29.5 HP*	Kawasaki® FX850 EFI

✔ 5YR/1200HR Limited Warranty\*\*  
First 2 years no hour limit.



**COMPACT STANCE**  
Perfect for tight spaces and  
trailing from job-to-job.



**VX DECK**  
Fabricated 7 GA steel deck, engineered  
for extreme vacuum performance and  
cut quality.

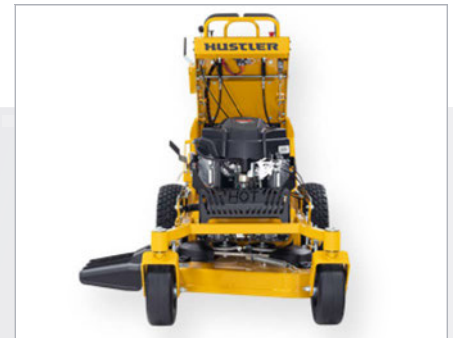

**SMOOTHTRAK™ STEERING**  
Precision control designed to help trim  
and maneuver easily around obstacles.

\*As rated by the engine manufacturer.

\*\*See owner's manual for warranty details and information. Certain restrictions apply.



# SUPER S

## PRODUCT FEATURES

- 1. PARK BRAKE**  
Hand operated lever to set the park brake.
- 2. CUT HEIGHT ADJUSTMENT**  
Hand operated lever and pin to adjust deck/cutting height.
- 3. SERVICE FRIENDLY DESIGN**  
Designed to make maintenance and service fast and easy.
- 4. PULLEY COVER**  
Toolless removable pulley covers for easy maintenance.
- 5. 24" REAR DRIVE TIRES**  
For superior Traction. (48", 52", 60")
- 6. ADJUSTABLE SPEED CONTROLS**  
Allows you to go at your own pace for control. Also helps with training new operators.
- 7. ADJUSTABLE FOOT PLATFORM**  
Spring loaded suspension platform designed for all-day comfort.
- 8. WIDE OPERATOR PLATFORM**  
For mowing comfort and operator stability.



# SUPER SF

DECK SIZE / ENGINE		
60"	38.5 HP*	Kawasaki® FX1000 EFI
60"	40 HP*	Vanguard® BigBlock™ EFI w/ Oil Guard
72"	38.5 HP*	Kawasaki® FX1000 EFI
72"	40 HP*	Vanguard® BigBlock™ EFI w/ Oil Guard

✓ 5YR/1200HR Limited Warranty\*\*  
First 2 years no hour limit.



**STRONG HYDRAULICS**  
Hydro-Gear® 21cc pumps  
and Parker TG wheel motors



**VX DECK**  
Fabricated 7 GA steel deck, engineered  
for extreme vacuum performance and  
cut quality.

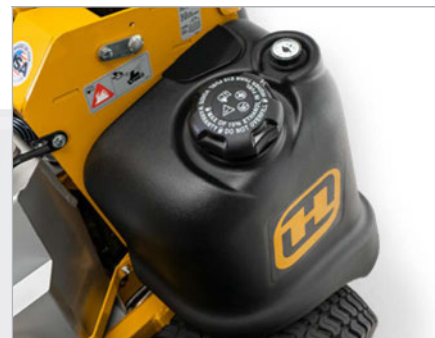

**DUAL FUEL TANKS**  
13.9" gal fuel capacity

\*As rated by the engine manufacturer.

\*\*See owner's manual for warranty details and information. Certain restrictions apply.



# SUPER SF

## PRODUCT FEATURES

- 1. SEMI PNEUMATIC FRONT TIRES**  
13" front tires.
- 2. ELECTRIC ACTUATOR DECK LIFT**  
Easily adjust your cutting height from 2.0" to 5.5".
- 3. 60" AND 72" VX DECKS**  
7 GA deckplate with 7 GA stamped spindle mounts and 11 GA bull nose leading edge.
- 4. HYDRO OIL COOLER**  
8" fan and 6-quart reservoir capacity.
- 5. KAWASAKI FX EFI AND VANGUARD EFI OIL GUARD ENGINES**  
38.5 and 40 HP\* options.
- 6. SERVICE FRIENDLY DESIGN**  
Designed to make maintenance and service fast and easy.
- 7. LARGE REAR TIRES**  
26" x 12" rear tires help with stability and traction.
- 8. SPEED CONTROL BAR ADJUSTMENT**  
Up to 15 MPH with reduced speed up to 10 MPH.





# TRIMSTAR

DECK SIZE / ENGINE		
36"	15 HP*	Kawasaki® FS541 Electric Start
48"	18.5 HP*	Kawasaki® FS600 Electric Start
54"	22 HP*	Kawasaki® FS651 Electric Start
60"	23 HP*	Kawasaki® FS691 Electric Start

✓ 5YR/1200HR Limited Warranty\*\*  
First 2 years no hour limit.



## WELDED STEEL DECK

10 GA plus 11 GA reinforced steel with 11 GA formed channel rolled edge (36" deck is 7 GA plus 11 GA reinforced steel).

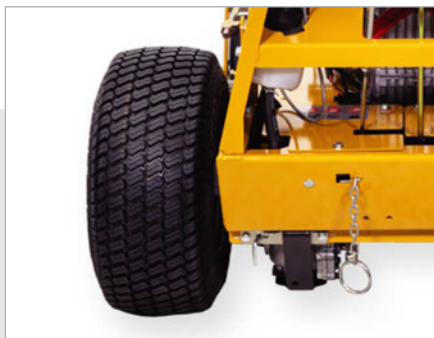

## DUAL HYDRO SYSTEM

Hydro-Gear ZT-2800® transmissions aid in traction and performance.



## COMPACT STANCE

Ideal for tight spaces and for trailering from job-to-job.

\*As rated by the engine manufacturer.

\*\*See owner's manual for warranty details and information. Certain restrictions apply.

# TRIMSTAR

## PRODUCT FEATURES

① **SMOOTHTRAK™ STEERING**

Precision control designed to help trim and maneuver easily around obstacles.

② **H-BAR® STEERING**

Patented H-Bar® Steering is easy-to-use, designed to minimize operator fatigue, and aid in training new operators

③ **3.4 US GALLON FUEL CAPACITY**

④ **DECK LIFT**

Easy-to-operate deck lift makes deck height adjustment a breeze.

⑤ **SERVICE FRIENDLY DESIGN**

Designed to make maintenance and service simple and easy.

⑥ **20" DRIVE TIRES**



# COMPARISON

## FASTRAK®



## FASTRAK® SDX



## X-ONE®



<b>DECK SIZE &amp; ENGINE</b>	48"	22 HP*	Kawasaki® FT691	<b>DECK SIZE &amp; ENGINE</b>	48"	22 HP*	Kawasaki® FT691	<b>DECK SIZE &amp; ENGINE</b>	52"	27 HP*	Kawasaki® FX850
	48" RD	22 HP*	Kawasaki® FT691		54"	22 HP*	Kawasaki® FT691		54" RD	27 HP*	Kawasaki® FX850
	48"	22 HP*	Kawasaki® FT691		60"	23.5 HP*	Kawasaki® FT730		60"	27 HP*	Kawasaki® FX850
	54"	22 HP*	Kawasaki® FT691						60" RD	27 HP*	Kawasaki® FX850
	54" RD	22 HP*	Kawasaki® FT691						60"	29.5 HP*	Kawasaki® FX850 EFI
	60"	24.5 HP*	Kawasaki® FT730						72"	27 HP*	Kawasaki® FX850 EFI
									72:"	29.5 HP*	Kawasaki® FX850 EFI
<b>DECK HEIGHT</b>	Foot-operated. 1.5" to 4.5" (1/4" increments).			<b>DECK HEIGHT</b>	Foot-operated. 1.5" to 4.5" (1/4" increments).			<b>DECK HEIGHT</b>	Foot-operated. 1.5" to 5.5" (1/4" increments).		
<b>DRIVE SYSTEM</b>	Commercial-duty Hydro-Gear ZT-3200™. Serviceable w / spin-on filters.			<b>DRIVE SYSTEM</b>	Commercial-duty Hydro-Gear ZT-3400™. Serviceable w / spin-on filters.			<b>DRIVE SYSTEM</b>	Hydro-Gear ZT-4400.		
<b>SPEED (FWD)</b>	Up to 10 MPH.			<b>SPEED (FWD)</b>	Up to 10 MPH.			<b>SPEED (FWD)</b>	Up to 12 MPH.		
<b>FUEL CAPACITY</b>	8.5 US gallons.			<b>FUEL CAPACITY</b>	8.5 US gallons.			<b>FUEL CAPACITY</b>	Dual fuel tank with 12 US gallon total capacity.		
<b>ACCESSORIES</b>	<ul style="list-style-type: none"> <li>▪ Mulch kit</li> <li>▪ Dump From Seat bagger (8 bushels)</li> <li>▪ Grass bagger (2-bag powered 7.2 bushels)</li> <li>▪ Mesh side bagger (3 bushels)</li> <li>▪ Steel side bagger (3.5 bushels)</li> <li>▪ Steering lever extension kit</li> <li>▪ FlexForks®</li> <li>▪ Light kit</li> <li>▪ Stripe kit</li> <li>▪ High vacuum kit</li> </ul>			<b>ACCESSORIES</b>	<ul style="list-style-type: none"> <li>▪ Mulch kit</li> <li>▪ Dump From Seat bagger (8 bushels)</li> <li>▪ Grass bagger (2-bag powered 7.2 bushels)</li> <li>▪ Mesh side bagger (3 bushels)</li> <li>▪ Steel side bagger (3.5 bushels)</li> <li>▪ Steering lever extension kit</li> <li>▪ FlexForks®</li> <li>▪ Light kit</li> <li>▪ Stripe kit</li> <li>▪ High vacuum kit</li> </ul>			<b>ACCESSORIES</b>	<ul style="list-style-type: none"> <li>▪ Semi pneumatic front tires</li> <li>▪ Steering lever extension kit</li> <li>▪ Deck rear anti-scalp wheels</li> <li>▪ 3-bag powered bagger (12 bushels)</li> <li>▪ BacVac bagger (10 bushels)</li> <li>▪ Mesh side bagger (3 bushels)</li> <li>▪ Steel side bagger (3.5 bushels)</li> <li>▪ Flex Forks®</li> <li>▪ Mulch kit</li> <li>▪ Light kit</li> <li>▪ Stripe kit</li> <li>▪ Electric deck lift</li> <li>▪ Hitch kit</li> <li>▪ Michelin® X® Tweel® Turf</li> </ul>		
<p>*As rated by the engine manufacturer</p> <p>Specifications are subject to change without notice.</p>											



# COMPARISON

## X-RIDE®



## SUPER Z®



## HYPERDRIVE®



## SUPER 104®



60" 34.5 HP\* Kawasaki® FX820 EVO EFI

54" 27 HP\* Kawasaki® FX850  
 60" 27 HP\* Kawasaki® FX850  
 60" 35 HP\* Kawasaki® FX1000  
 60" 35 HP\* Kawasaki® FX1000 (VX Deck)  
 60" RD 35 HP\* Kawasaki® FX1000  
 60" 38.5 HP\* Kawasaki® FX1000 EFI  
 72" 35 HP\* Kawasaki® FX1000  
 72" RD 35 HP\* Kawasaki® FX1000  
 72" 38.5 HP\* Kawasaki® FX1000 EFI

54" 35 HP\* Kawasaki® FX1000  
 60" 35 HP\* Kawasaki® FX1000  
 60" 38.5 HP\* Kawasaki® FX1000 EFI  
 60" 38.5 HP\* Kawasaki® FX1000 EFI (VX Deck)  
 60" RD 38.5 HP\* Kawasaki® FX1000 EFI  
 60" 40 HP\* Vanguard® BigBlock EFI  
 72" 35 HP\* Kawasaki® FX1000  
 72" 38.5 HP\* Kawasaki® FX1000 EFI  
 72" RD 38.5 HP\* Kawasaki® FX1000  
 72" 40 HP\* Vanguard® BigBlock EFI

104" RD 40 HP\* Vanguard® BigBlock EFI  
w / Oil Guard  
 104" RD 38.5 HP\* Vanguard® BigBlock EFI  
w / Oil Guard

Foot-operated.  
 1.5" to 5.5" (1/4" increments).

Foot-operated.  
 1.5" to 5.5" (1/4" increments).

Foot-operated.  
 1.5" to 5.5" (1/4" increments).

Hydraulic.  
 1" to 5.5" (1/4" increments)

Hydro-Gear ZT-5400™.

Hydro-Gear 21cc pumps, Parker TG high torque wheel motors, 3 gal. reservoir, oil cooler w/ fan & hot oil shuttle.

HyperDrive industrial Danfoss slipper piston pumps, Parker TG high torque wheel motors, 3 gal. reservoir, oil cooler w/ 9" fan & hot oil shuttle.

HyperDrive industrial Danfoss slipper piston pumps, Parker TG high torque wheel motors, 3 gal. reservoir, oil cooler w/ 9" fan & hot oil shuttle.

Up to 13 MPH.

Up to 14 MPH.

Up to 16 MPH.

Up to 11 MPH.

12 US Gallons.

Dual fuel tank with 12 US gallon total capacity.

Dual fuel tank with 12 US gallon total capacity.

15 US Gallons.

- Mulch kit
- Dump From Seat bagger (8 bushels)
- Grass bagger (2-bag powered 7.2 bushels)
- Mesh side bagger (3 bushels)
- Steel side bagger (3.5 bushels)
- Steering lever extension kit
- FlexForks®
- Light kit
- Stripe kit
- High vacuum kit

- Semi pneumatic front tires
- Steering lever extension kit
- Deck rear anti-scalp wheels
- 3-bag powered bagger (12 bushels)
- BacVac bagger (10 bushels)
- Flex Forks®
- Mulch kit
- Light kit
- Sand kit
- Stripe kit
- Beacon kit
- Flasher kit
- Electric deck lift
- Hitch kit
- Michelin® X® Tweel® Turf

- Semi pneumatic front tires
- Steering lever extension kit
- Deck rear anti-scalp wheels
- 3-bag powered bagger (12 bushels)
- BacVac bagger (10 bushels)
- Flex Forks®
- Mulch kit
- Light kit
- Sand kit
- Stripe kit
- Beacon kit
- Flasher kit
- Electric deck lift
- Hitch kit
- Michelin® X® Tweel® Turf

- Semi pneumatic front tires
- Steering lever extension kit
- Flex Forks®
- Mulch kit
- Light kit
- Beacon kit
- Flasher kit
- Hitch kit
- Anti-scalp kit

 Visit [hustlerturf.com](http://hustlerturf.com) for more specs.

# COMPARISON

## DIESEL Z



## SURFER PRO



## SUPER S<sup>®</sup>



<b>DECK SIZE &amp; ENGINE</b>	60"	25 HP*	Perkins <sup>®</sup>	36"	15 HP*	Kawasaki <sup>®</sup> FS541	36"	19HP*	Kawasaki <sup>®</sup> FX600		
	60" RD	25 HP*	Perkins <sup>®</sup>		48"	15 HP*		Kawasaki <sup>®</sup> FS541	48"	22 HP*	Kawasaki <sup>®</sup> FX691
	72"	25 HP*	Perkins <sup>®</sup>						52"	27 HP*	Kawasaki <sup>®</sup> FX850
	72"	25 HP*	Perkins <sup>®</sup>						52"	29.5 HP*	Kawasaki <sup>®</sup> FX850 EFI
							60"	27 HP*	Kawasaki <sup>®</sup> FX850		
							60"	29.5 HP*	Kawasaki <sup>®</sup> FX850 EFI		
<b>DECK HEIGHT</b>	Foot-operated. 1.5" to 5.5" (1/4" increments).			Hand-operated. 2" to 4.75" (1/4" increments).			Hand-operated. 1.5" to 5.5" (1/4" increments).				
<b>DRIVE SYSTEM</b>	Tandem Hydro-Gear 21 cc pumps, Parker TG wheel motors, oil cooler with 8" fan.			Hydro-Gear ZT-1800			<b>36"</b> : Hydro-Gear 10 cc pump and Parker TL wheel motor.  <b>48/52/60"</b> : Hydro-Gear 12 cc pump and Parker TL wheel motor.				
<b>SPEED (FWD)</b>	Up to 11.5 MPH.			Up to 6 MPH.			<b>36"</b> : Up to 8 MPH <b>48/52/60"</b> : Up to 9 MPH				
<b>FUEL CAPACITY</b>	14.4 US gallons.			2 US gallons.			<b>36"</b> : Up to 6.5 MPH <b>48/52/60"</b> : Up to 7.3 MPH				
<b>ACCESSORIES</b>	<ul style="list-style-type: none"> <li>▪ Semi pneumatic front tires</li> <li>▪ Steering lever extension kit</li> <li>▪ Single/dual anti-scalp wheels</li> <li>▪ Flex Forks<sup>®</sup></li> <li>▪ Mulch kit</li> <li>▪ Light kit</li> <li>▪ Sand kit</li> <li>▪ Stripe kit</li> <li>▪ Beacon kit</li> <li>▪ Flasher kit</li> <li>▪ Electric deck lift</li> <li>▪ Hitch kit</li> <li>▪ Michelin<sup>®</sup> X<sup>®</sup> Tweel<sup>®</sup> Turf</li> </ul>			<ul style="list-style-type: none"> <li>▪ Mulch kit</li> <li>▪ Mesh side bagger (3 bushels)</li> <li>▪ Light kit</li> <li>▪ Stripe kit</li> </ul>			<ul style="list-style-type: none"> <li>▪ Mesh side bagger (3 bushels)</li> <li>▪ Steel side bagger (3.5 bushels)</li> <li>▪ Mulch kit</li> <li>▪ Light kit</li> <li>▪ Stripe kit</li> <li>▪ Trash basket</li> <li>▪ Cup holder</li> </ul>				
<p>*As rated by the engine manufacturer</p> <p>Specifications are subject to change without notice.</p>											



# COMPARISON

## SUPER SF



## TRIMSTAR®



60"	38.5 HP*	Kawasaki® FX1000 EFI
60"	40 HP*	Vanguard® BigBlock EFI w / Oil Guard
72"	38.5 HP*	Kawasaki® FX1000 EFI
72"	40 HP*	Vanguard® BigBlock EFI w / Oil Guard

36"	15 HP*	Kawasaki® FS541
48"	18.5 HP*	Kawasaki® FS600
54"	22 HP*	Kawasaki® FS651
60"	23 HP*	Kawasaki® FS691

Hand-operated.  
2" to 5.5" (1/4" increments).

Foot-operated.  
1.5" to 4.5" (1/4" increments).

Hydro-Gear 21cc pumps and  
Parker TG wheel motors.

Hydro-Gear ZT-2800®  
w / spin-on filters.

Up to 15 MPH.

Up to 6.3 MPH.

13.9 US gallons.

3.4 US gallons.

- Mulch kit
- Mesh side bagger (3 bushels)
- Light kit
- Stripe kit
- Mud Flap kit

- Mulch kit
- Mesh side bagger (3 bushels)
- Steel side bagger (3.5 bushels)
- Stripe kit
- High vacuum kit



## HUSTLER FLUID PRODUCTS

Hustler Turf's motor oil, fuel stabilizer, and hydrostatic transmission oil products will help keep your machine running smoothly. Ask your local dealer about availability of these products.



Visit [hustlerturf.com/find-a-retailer](http://hustlerturf.com/find-a-retailer) to locate your nearest dealer.

# ACCESSORIES & OTHER PRODUCTS (EACH SOLD SEPARATELY)



## 2-BAG POWERED BAGGER

Bagger has a 7.2-bushel capacity. Available on FasTrak® and FasTrak® SDX.



## 3-BAG POWERED BAGGER

Bagger has a 12-bushel capacity. Available on X-ONE®, Super Z®, and HyperDrive®.



## STEEL SIDE BAGGER

Bagger has a 3.5-bushel capacity. Available on FasTrak, FasTrak SDX, X-ONE, Super S®, and TrimStar®.



## MESH SIDE BAGGER

Electric actuated DFS bagger system. The BACVAC has a 10-bushel capacity. Available on X-ONE, Super Z, and HyperDrive.



## BACVAC

Electric actuated DFS bagger system. The BACVAC has a 10-bushel capacity. Available on X-ONE, Super Z, and HyperDrive.



## MICHELIN® X® TWEEL® TURF

Airless radial tires designed to help minimize downtime caused by flat tires and unseated beads. Available on X-ONE, Super Z, HyperDrive, and Diesel Z.



## FLEX FORKS®

Designed to provide operator comfort and an even cut, especially over uneven terrain or at high speeds.



## MULCH KIT

Recycles clippings back into the soil to reclaim nutrients for your lawn.



## STEERING EXTENSION KIT

Allows for height adjustment of steering levers to help make your mowing experience as comfortable as possible.



## LIGHT KIT

Help extend productivity into late hours. Kit contains two high-quality 12-volt lights with a switch that mounts in the instrument panel.



## STRIPE KIT

Helps provide a professional, manicured finish to your lawn. Depending on the mower, rubber flap or steel cylinder options are available.



## SEMI-PNEUMATIC TIRES

Designed to help protect against flat tires.



# FLEET PROGRAM

The Hustler fleet program is one of the most aggressive in the industry. We value loyalty and reward our customers for it. To qualify, you only need to purchase 2 units.

Once you're in the program, your fleet pricing is good for a rolling 12 months. Add a unit to your fleet in that time and your 12 months starts over.



# OF UNITS PURCHASED	FLEET DISCOUNT
2 Units	25% off MSRP
4 or More Units	27% off MSRP

## ELIGIBILITY:

Customers who purchase 2 or more eligible products on the same invoice.

## DETAILS & GUIDELINES:

- If you purchase an additional eligible unit within 12 months of the original invoice date, the same rebate % originally paid per unit will be applied.
- You can continue to extend your fleet discount with purchase of at least one eligible unit during each subsequent 12-month period.
- This additional sale does not increase the original number of units sold. You retain your original bracket discount, subject to current published MSRP at the time of additional sale.
- Retail financing may be used unless otherwise stated in program.
- Programs cannot be used in conjunction with other rebates or promotions unless specifically stated.

## ELIGIBLE UNITS:

FasTrak (2021 model and newer)  
FasTrak SDX  
X-ONE  
X-RIDE  
Super Z  
Super Z HyperDrive  
Hustler Diesel Z  
TrimStar  
Super S  
Super 88  
Super 104\*  
Super SF  
Surfer Pro\*\*

# IT'S A MENTALITY



SCAN TO VIEW VIDEO



# NOTES

A series of horizontal lines for writing notes, starting from the top of the page and extending to the bottom.







# HUSTLER®

KAWASAKI IS A REGISTERED TRADEMARK OF KAWASAKI HEAVY INDUSTRIES, LTD  
KOHLER IS A REGISTERED TRADEMARK OF KOHLER CO  
VANGUARD IS A REGISTERED TRADEMARK OF BRIGGS & STRATTON CORPORATION  
MICHELIN IS THE REGISTERED TRADEMARK OF MICHELIN & CIE  
HYDRO-GEAR IS A REGISTERED TRADEMARK OF HYDRO-GEAR LTD

©2024 HUSTLER TURF EQUIPMENT

SPECIFICATIONS SUBJECT TO CHANGE WITHOUT NOTICE.  
VISIT [WWW.HUSTLERTURF.COM](http://WWW.HUSTLERTURF.COM) FOR THE MOST CURRENT  
SPECIFICATIONS. 773-10444 | 04-20

**[HUSTLERTURF.COM](http://HUSTLERTURF.COM)**

